

«CC» -

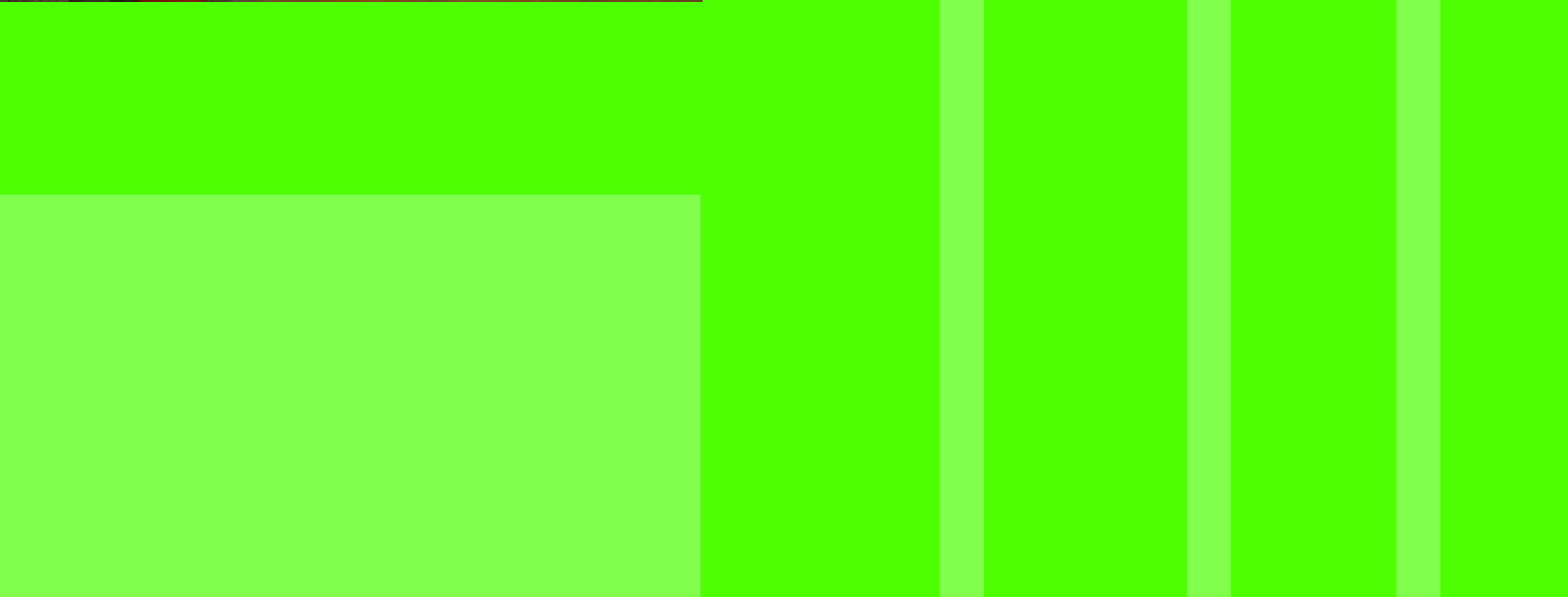

Compactors | Auger Compactors | Balers | Transfer and Shifting Stations | Bin Lifters



«CC» -

PRESTO

«CC»

PRESTO.

PRESTO



PRESTO



« - »

PLC

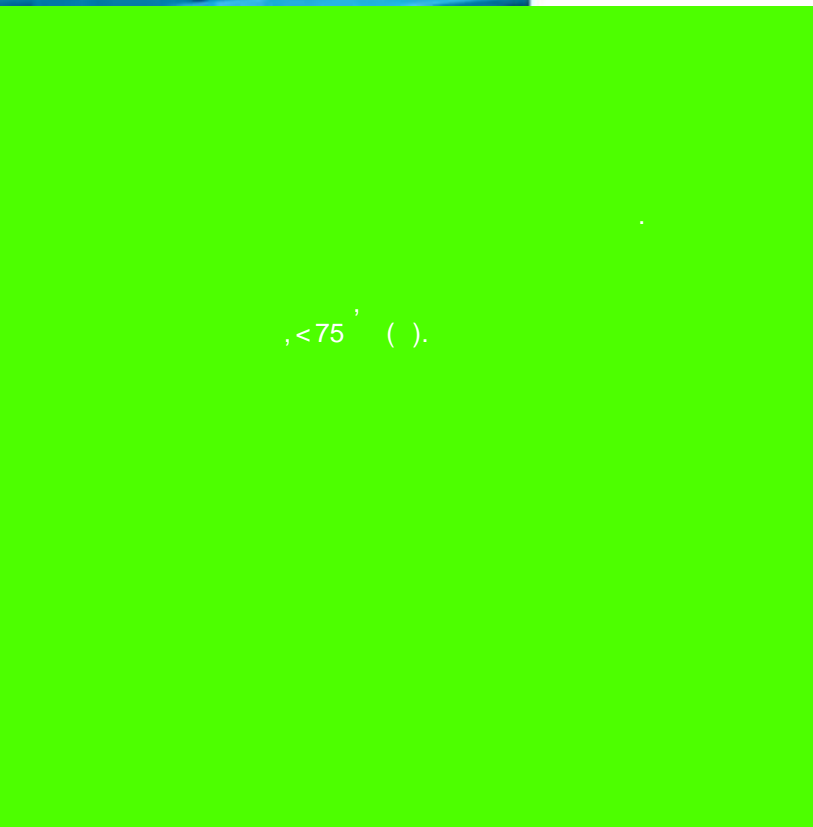

«CC»

PRESTO

, <75' ( ).

«CC» -

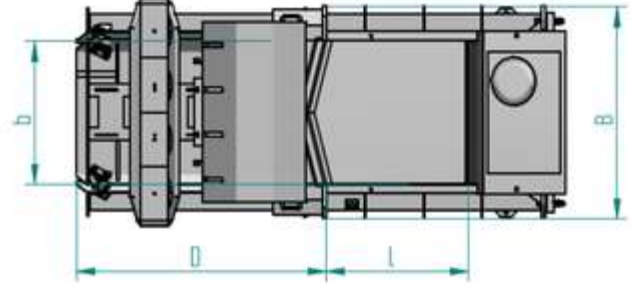
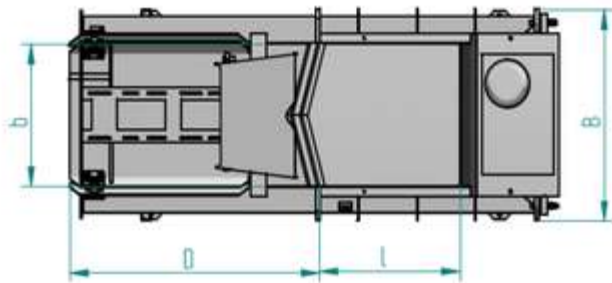
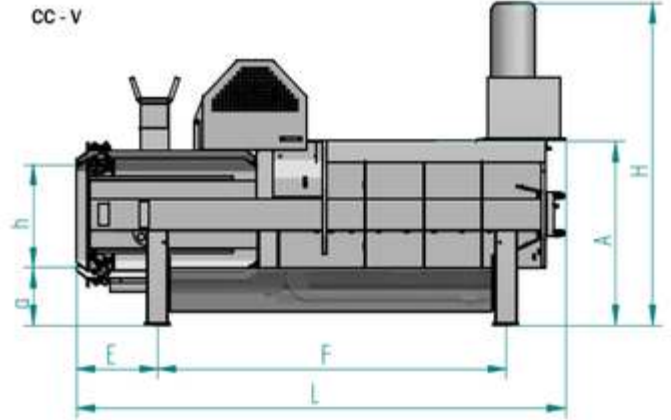
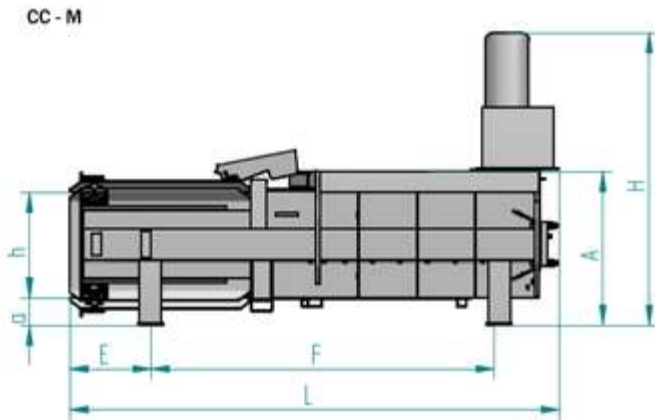

		CC 13 V	CC 13 M	CC 20 V	CC 20 M	CC 30 V	CC 30 M	CC 40 V	CC 40 M
(L)	mm	2 650	2 650	3 140	3 140	3 550	3 550	3 600	3 600
(B)	mm	1 150	1 150	1 210	1 210	1 410	1 410	1 580	1 580
(S)	mm	4150 2350	4150 2350	4640 2410	4640 2410	5050 2610	5050 2610	5100 2780	5100 2780
(H)	mm	1 850	1 640	2 060	1 850	2 150	1 940	2 210	2 200
A	mm	1 225	1 025	1 225	1 025	1 225	1 025	1 275	1 075
	mm	750 750	750 750	1000 750	1000 750	1030 950	1030 950	1030 1100	1030 1100
	mm	700 750	700 750	700 750	700 750	700 950	700 950	750 1100	750 1100
	m <sup>3</sup>	0,39	0,39	0,53	0,53	0,69	0,69	0,85	0,85

**Volumenleistung bezogen auf Schüttgewicht**

35 / ... ( )		50	37	77	47	58	42	71	51
	kN	130	130	200	200	300	300	400	400
	kN/m <sup>2</sup>	248	248	381	381	450	450	485	485
	S	24	24	24	24	34	34	34	34
	HB.	3	3	3	3	4	4	4	4

**Gewichtsleistung bezogen auf Schüttgewicht**

35 / ... ( )		1,7	1,3	2,2	1,6	2	1,5	2,5	1,8
60 / ... ( )		2,5	1,7	3,4	2,3	3,2	2	4	2,5
100 / ... ( )		3,8	2,2	4,8	2,8	4,8	2,5	5,9	3,1
	kg	250	250	300	300	350	350	400	400
	kg	1900	1600	2700	2400	3700	3200	4200	3700
	KW	5,5	5,5	7,5	7,5	11	11	15	15

3 L / N / PE; 400 V, 50 Hz